

948L-III GRAPPLE SKIDDER



JOHN DEERE



RELIABLE WARRIOR IN THE WOODS.

When loggers like you tell us what they need to succeed in the woods and at the landing, we listen and then get to work putting ideas into action. Based on some of your best input, the John Deere 948L-III Grapple Skidder boasts new operator assistance, productivity awareness, and feedback features. And refinements in jobsite-mapping capability and machine maintenance help make it efficient to operate and reliable to own. The 948L-III is purpose-built to take on tough forestry tasks and come back for more.

Best of both worlds

Continuously Variable Transmission (CVT) combines the efficiency of direct drive with the smoothness and operating ease of hydrostatic drive. Automatically sensing the load, CVT delivers torque and tractive effort as needed to maintain the maximum speed the operator sets, helping reduce engine wear, optimize fuel economy, and eliminate manual shifting.

Take control in comfort

Spacious and quiet standard cab boasts an adjustable new durable-cloth seat and integrated TimberMatic™ Maps. Premium cab option includes set-and-forget Automatic Temperature Control system, cameras, secondary display unit, and other operator-assistance features. Optional premium leather seat that's heated, vented, and adjustable seven ways takes operator comfort to the next level. Operators are now able to select three different seat positions including facing the right-side door.

See things like never before

Available with the premium cab package, new blade-view camera enables clear visibility to attachments as you work the jobsite. Secondary touch-screen display provides intuitive access to cameras, slope details, and machine information.

Effortless operation

Armrest-mounted electrohydraulic controls provide easy, fingertip operation of all machine functions.



**NEAR-REAL-TIME
PRODUCTIVITY DETAILS
HELP BOOST EFFICIENCY**

Protective cushioning

Steering sensors control articulation speed when nearing frame-to-frame contact, cushioning impact during full articulation and enhancing operator comfort.

Stable and capable

Rock-solid stability provides excellent pulling power, especially when climbing hills, navigating adverse terrain, or hauling bigger payloads.

Productive as you run

Digital solutions that monitor operator work statistics, travel/trip-meter capability, and advanced map layers help keep track of important operational basics. Near-real-time production and operator-performance reporting to business owners and managers allows informed analysis of owning and operating costs.

Get ready for rugged

Standard Outboard-Extreme™ axles are designed with larger components to deliver maximum jobsite durability, along with a heavier weight to boost machine stability.

Large and in charge

Optional 2.07-square-meter (22.3 square foot) grapple on the 948L-III helps you deliver more wood to the landing with fewer skids.

948L-III GRAPPLE SKIDDER

***PUT TECHNOLOGY TO WORK
IN THE WOODS AND AT THE OFFICE.***

Coordinate your operation and your team's productivity from wherever your work takes you with John Deere Precision Forestry and our core technology solutions.

FEATURES

Core intelligence

Your John Deere Forestry machine arrives from the factory equipped with a powerful set of technologies and capabilities already built in. Each plays an important role in managing the health and performance of your overall equipment fleet:

- **John Deere Connected Support**, utilizing advanced, forestry machine-specific data, helps your dealer take immediate action on any issues with your machine.
- **Remote Display Access** allows dealers to remotely see exactly what the operator is seeing and access the vast onboard diagnostics capabilities of the TimberMatic™ automation system. The ability to adjust the machine and assist the operator remotely helps keep machines up and running.
- The **Machine Health and Performance Monitoring** service is offered in conjunction with advanced John Deere Protect™ Service Agreements. By utilizing advanced forestry machine data and benchmarking capabilities, this service provides unparalleled insights into different machine functions and helps take corrective actions early, ensuring a consistently high-performing fleet.

Digital solutions

Take the guesswork out of planning, implementing, and monitoring your logging operation. The tools of our production-planning and -tracking system expand on the core technology features that come standard in every John Deere Forestry machine to unleash a powerful new array of possibilities:

- **TimberMatic™ Maps** is an innovative onboard software solution that helps you reimagine your jobsites. Near-real-time production views, optimized routes, and a shared cloud connection make it easier than ever before to take your forestry operation to the next level.
- **TimberManager™** is a web-based solution for PCs, tablets, and mobile phones that allows you to follow jobsite progress. Combined with TimberMatic Maps, this software provides complete visibility of your operation — from land harvested to specific machines — so you can streamline communication, analyze tasks, and increase productivity:
 - **Remote Monitoring** keeps tabs on the health and performance of your fleet from wherever you are.
 - **Precise Progress Tracking** lets you set goals for your team to meet throughout the day.
 - **Live Production View** displays progress including tree count, area harvested, and estimated tonnage.
 - **Simplified Mapping** of machine data and GPS-based location tracking shows precise stem and log counts.
 - **Real-Time Updates** let you adjust course or eliminate tasks if needed to maintain steady workflow.
 - **Fleet Optimization** goes beyond machine management to help improve the efficiency of your business.



**JOHN DEERE
CONNECTED SUPPORT™**

CONNECTS YOUR OPERATION
TO DEALER & FACTORY EXPERTISE

948L-III GRAPPLE SKIDDER SPECIFICATIONS

Engine			
Manufacturer / Model	John Deere PowerTech™ PSS 9.0L	John Deere PowerTech™ Plus 9.0L	
Non-Road Emission Standards	EPA Final Tier 4/EU Stage V	EPA Tier 3/EU Stage IIIA	
Gross Power	224 kW (300 hp) at 1,800 rpm	224 kW (300 hp) at 1,800 rpm	
Gross Torque	1369 Nm (1,009 ft.-lb.) at 1,400 rpm	1300 Nm (959 ft.-lb.) at 1,400 rpm	
Number of Cylinders	6	6	
Valves per Cylinder	4	4	
Engine Displacement	9.0 L (549 cu. in.)	9.0 L (549 cu. in.)	
Engine Bore and Stroke	118.4 x 136 mm (4.66 x 5.35 in.)	118.4 x 136 mm (4.66 x 5.35 in.)	
Fuel System	High-pressure common rail	High-pressure common rail	
Aspiration	Turbocharged and charge-air cooled	Turbocharged and charge-air cooled	
Air Cleaner	Dual stage with safety element	Dual stage with safety element	
Engine Cold-Start System	Auto ether	Auto ether	
Cooling			
Cooling System	Heavy-duty radiator with continuous deaeration tank and recovery reservoir		
Fan Drive	Hydraulic, variable speed, reversing		
Powertrain			
Transmission	Continuously Variable Transmission (CVT)		
Speed Ranges, Forward and Reverse	6		
Maximum Travel Speed With 35.5-32 Tires	Forward and Reverse		
Range 1 (factory settings for each speed range)	4.91 km/h (3.05 mph)		
Range 2	6.44 km/h (4.00 mph)		
Range 3	8.27 km/h (5.14 mph)		
Range 4	12.29 km/h (7.64 mph)		
Range 5	18.02 km/h (11.20 mph)		
Range 6	25.00 km/h (15.53 mph)		
Axles	1700 Outboard-Extreme™		
Front Axle Oscillation, Stop to Stop	30 deg.		
Differential (front and rear)	Hydraulic-locking, operated-on-the-go, open-center differential lock		
Steering	Fully hydraulic, joystick		
Articulation Angle	45-deg. each direction		
Service Brakes	Inboard-mounted, wet-disc, oil-cooled, self-adjusting and self-equalizing front and rear axles		
Parking Brake	Automatically spring-applied, hydraulically released, sealed and lubricated, wet multi-disc		
Hydraulics			
Main Pump	Open circuit, axial piston, variable displacement		
Maximum Displacement	85 cc/rev (5.19 ci/rev)		
Electrical System			
Voltage	24 volt		
Number of Batteries (12 volt)	2		
Battery Capacity (each)	950 CCA		
Alternator Rating	150 amp		
Worklights	11 standard / 15 optional with 3 service lights		
Dual-Function Grapples			
Grapple Control	Joystick	Grapple Control (<i>continued</i>)	Joystick
Standard		Optional	
Opening	3785 mm (149 in.)	Opening	3886 mm (153 in.)
Area	1.77 m ² (19.1 sq. ft.)	Area	2.07 m ² (22.3 sq. ft.)
Refill Capacities			
Fuel Tank			
Standard	391.8 L (103.5 gal.)		
Optional Large	457.7 L (120.9 gal.)		
Hydraulic Reservoir	123.6 L (32.6 gal.)		
Diesel Exhaust Fluid (DEF) Tank	19.9 L (5.2 gal.)		
Operating Weight			
Machine Weight	23 094 kg (50,913 lb.)		
Dozer Blade			
Type	Heavy-Duty Stacking Blade	Heavy-Duty Replaceable Cutting Edge (RCE)	
Width	2962.4 mm (116.6 in.)	2962.4 mm (116.6 in.)	
Height	687.6 mm (27.1 in.)	691.0 mm (27.2 in.)	
Blade Control	Joystick	Joystick	

Images and descriptions are for general information only. Some illustrations may depict product options or accessories NOT AVAILABLE in all regions or may require modifications to meet local regulations. Images of equipment models may be digitally or AI generated, are for illustration purposes only, and may not reflect actual products, features, options, or attachments. Equipment availability may be limited. For complete details, contact your John Deere dealer.

Boom Options		948L-III	
Size	3.1-m (10.2 ft.) standard		
Winch			
Winch Control	Joystick control, hydraulically driven		
Cable Capacity	2-Speed 6000 Winch With 279.5-mm (11.00 in.) Drum	2-Speed 4000 Winch With 204-mm (8.03 in.) Drum	
15.8 mm (5/8 in.)	119.0 m (390 ft.)	77.4 m (252 ft.)	
19.1 mm (3/4 in.)	81.4 m (267 ft.)	54.6 m (177 ft.)	
22.2 mm (7/8 in.)	60.3 m (197 ft.)	39.3 m (128 ft.)	
25.4 mm (1 in.)	46.0 m (150 ft.)	30.7 m (100 ft.)	
Line Pull – 15.8-mm (5/8 in.) Cable	<i>Bare Drum at Stall With 2-Speed 6000 Winch</i>	<i>Bare Drum at Stall With 2-Speed 4000 Winch</i>	
Low Speed	221.0 kN (49,696 lb.)	213.5 kN (47,997 lb.)	
High Speed	147.3 kN (33,131 lb.)	142.3 kN (31,990 lb.)	
Line Speed – 15.8-mm (5/8 in.) Cable	<i>Bare Drum at 1,800 rpm With 2-Speed 6000 Winch</i>	<i>Bare Drum at 1,800 rpm With 2-Speed 4000 Winch</i>	
Low Speed	13.4 m/min (44 fpm)	13.4 m/min (44 fpm)	
High Speed	20.1 m/min (66 fpm)	20.1 m/min (66 fpm)	
Machine Dimensions		Machine Dimensions (continued)	
Tire Size	Dual Function 35.5-32	Tire Size	Dual Function 35.5-32
A Overall Height	3454 mm (136.0 in.)*	H Overall Length	8890 mm (350.0 in.)*
B Overall Width	3575 mm (140.7 in.)	Shipping Dimensions	
C Maximum Blade Lift Above Ground	1578 mm (62.1 in.)	Tire Size	35.5-32
D Maximum Blade Dig Below Ground	298 mm (11.7 in.)	Overall Height	3454 mm (136.0 in.)
E Dozer Blade Width	2962.4 mm (116.6 in.)	Overall Width	3575 mm (140.7 in.)
F Wheelbase	3975 mm (156.5 in.)	Shipping Length	9982 mm (393.0 in.)*
G Ground Clearance	604 mm (23.7 in.)	*Length based on 3.1-m (10.2 ft.) boom.	

948L-III Grapple Skidder With Dual-Function Grapple

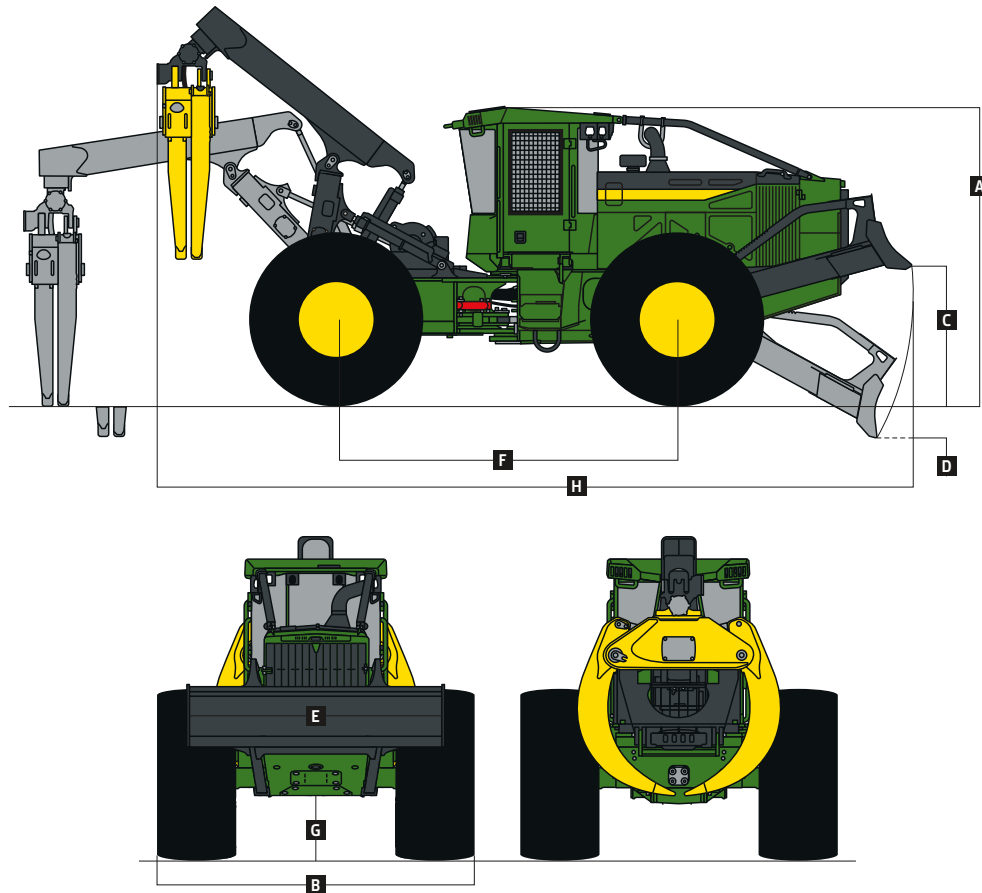

Images and descriptions are for general information only. Some illustrations may depict product options or accessories NOT AVAILABLE in all regions or may require modifications to meet local regulations. Images of equipment models may be digitally or AI generated, are for illustration purposes only, and may not reflect actual products, features, options, or attachments. Equipment availability may be limited. For complete details, contact your John Deere dealer.



MSK948LIIIU (25-09)



JOHN DEERE